

# Craftsmans—Corner

Edited by Chuck Larsen, Designee Director

**I**N EARLY 1973 Val sent EAA the plans for this one evening project he had built for his aircraft. It was first published in the DESIGNEE NEWSLETTER\* that same year and has since been reproduced in a number of Chapter newsletters and builder's publications.

The present "store bought" price of nearly \$30.00

for a commercially manufactured skid-slip indicator make this inexpensive, functional project worthwhile from an economic standpoint, as well as the satisfaction of building it yourself.

This full size template and drawing provide the information necessary to build this handy little instrument.

## HOMEBUILT SKID-SLIP INDICATOR

By Val Bernhardt (EAA 59376)  
EAA Chapter 133  
4800 S.W. 18th Street  
Ft. Lauderdale, Florida 33317

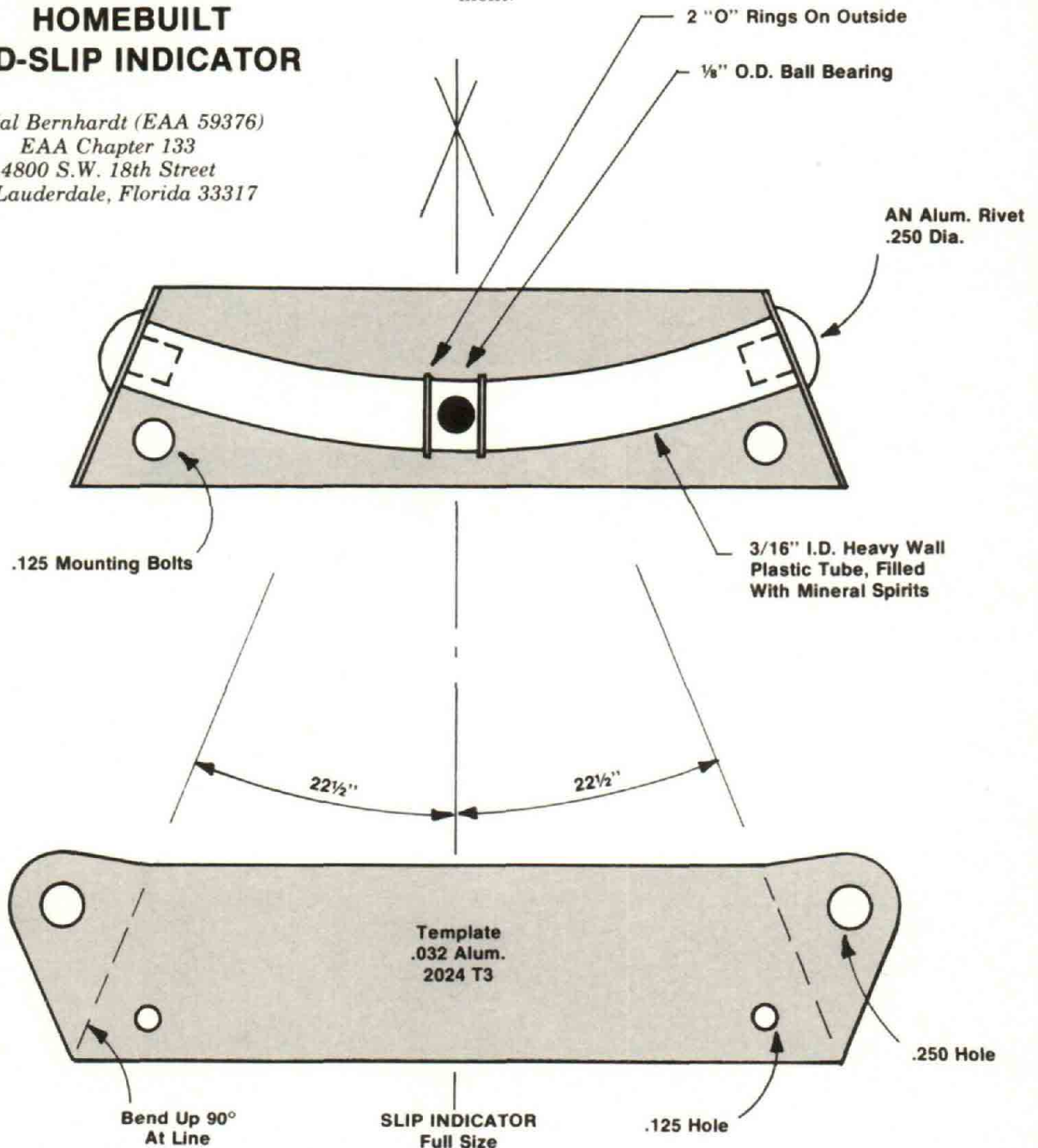

\*The DESIGNEE NEWSLETTER is a monthly EAA publication containing building tips, technical and other information of interest to EAA Designees, aircraft builders and restorers. It is available to current EAA members for the annual subscription rate of \$10.00 per year. A sample of a recent DESIGNEE NEWSLETTER for your review will be sent for just \$1.25. Address subscription or requests for samples to the DESIGNEE NEWSLETTER at EAA Headquarters enclosing the appropriate remittance.