



Self-Assembly Buildings

302 Beverly Rd
Newark, DE 19711
Phone/fax 302/368-0427
www.pan.cc

CONSTRUCTION GUIDE

BUILD YOUR OWN INSULATED STORAGE HANGAR

for under \$2/sq.ft.

Uses

- refugee shelters
- yard storage
- boats
- aircraft
- pools
- poultry

CONTENTS

Essentials
General guidelines
Materials & sources
Purchase options
Hangar check list
Steps
Materials for 10 hangars
Parts views
Assembly tools
Assembly
Assembly options
Maintenance tips
About Panel Inc.

ESSENTIALS

This guide shows how to assemble hangars from 12 to 40 ft. span by any length for under \$2/sq.ft. (see material costs in Table 1).

Uses. Refugee shelters, yard storage, pool or tennis court enclosures, boat, plane and equipment storage, poultry houses, farm buildings, and uses in remote areas to reduce transportation costs.

Materials. Steel pipe purlins on PVC pipe arch ribs, with polyester tensile strapping to resist wind racking and snow loads. The frame is covered with 3/8" fanfold insulation board and exterior grade woven film.

Performance. The hangars flex under winds and snows, like a greenhouse frame. Maintenance includes checking the strapping for tension, and replacing the film cover after 10 years or so of sun exposure.

Economy. They are economical where minor insulation is needed to prevent condensation dripping onto equipment and to reduce daily temperature cycling. Yearly costs are comparable to those of greenhouses, since the film cover needs replacing less often.

Tax advantages. Since the hangars are easily disassembled and compactly moved, they have the business income tax and real estate tax advantages of temporary buildings.

Labor. They can be assembled by one person, although hangars greater than 30 ft. span are assembled more easily by two, due to component sizes. One person can assemble a 20x20' hangar in 4-6 hrs.

Sizes. Table 1 lists materials for ten hangar sizes. The hangars are designed to require just a few widely available materials in common sizes, to minimize waste and material cost. Roof films and rib lengths are in 10' increments. Materials are available in the U.S and foreign building supply stores.

To see if one of the hangars fits your need, complete the HANGAR CHECK LIST. Then choose a hangar size from Table 1. Multiply the quantity of each material for your hangar size by its local price to obtain total cost. Compare unit prices with the typical U.S. prices listed.

The photo-illustrated instructions guide you through assembly. Check the building codes for your location and use.

GENERAL GUIDELINES

These guidelines apply to all hangar sizes, including those in Table 1.

1. Select a rib PVC electrical conduit size approximately 1" dia. for each 20' of rib length, i.e. 2.5" for 50' long ribs. Select a ground socket size at least 1/2" larger, for nesting. PVC plumbing pipe, PVC electrical conduit, and ABS sewer pipe all serve well. ABS is cheapest.
2. Film size determines hangar size, because other components can be easily adjusted in size: pipe lengths are quickly sawn, and fanfold cut to length and lapped by any amount to cover the length of the roof.
3. Space the two end ribs about 1.5' closer than the film length, to allow tightening the film down over the roof ends. Then space intermediate ribs no more than 7'. This gives a rib and sub-rib spacing to support the edge of each 4' wide fanfold with at least a 6" lap. Closer rib spacing is OK.
4. Framing can be done on windy days. Covering the roof with fanfold and film requires calm weather.
5. Although specific materials, dimensions, and procedures are described, you will recognize substitutions, depending upon local material and labor availability.

MATERIALS

Fig. 1 shows materials listed in Table 1. Fig. 2 separates them by type: i.e. pipes, lumber, tension strapping, and cover materials. Fig. 3 shows plan and elevation views.

The PVC pipe ribs allow easy bending, sawing, drilling, attachment of framing and cladding by screws or bolts, and transportation in straight bundles, unlike bent steel pipe arch ribs.

The fanfold (1) allows rapid hangar enclosure by a single person, (2) insulates to reduce diurnal temperature swings and the resulting moisture condensation which corrodes equipment, and (3) lengthens the life of the film cover by providing continuous support to reduce wind stress and pockets of rain which may otherwise collect between framing members near the hangar top.

The roof film allows rapid coverage of large areas by one person, without concern for water-tightness at joints, and a fast means to wind-anchor the entire hangar. Films are silver/black 6 oz 11-12 mil UV-coated 14x14 woven polyethylene (see **Material sources**). Or select a film based on your own need, cost, and availability.

The construction materials and method are forgiving of errors in measurement. Sockets can be relocated or realigned, the PVC ribs can be sawn or the stop nails moved along the rib to accommodate film width. Ribs are rapidly drilled or re-drilled for nails and bolts. The fanfold is easily lengthened by taping added sections or shortened by cutting with a knife.

Material sources

Most materials are available at building supply stores like Home Depot. Use the following phone numbers to locate material suppliers near you.

Part	Material	Source	Product No.	Phone
f15	Polypropylene strapping and strapping buckles	Rand Corp.	C1816V3 C1650B3	800-366-2300
c1	Fanfold insulation	Georgia Pacific Owens Corning		770-221-2232 800-267-8787
c4,5	Roof film & ground tarps	Electra Tarp Grosport Mfgrg.		330-477-7702 800-457-4406

Make needed material substitutions depending on local availability. Here are some examples:

Part Material substitution

f2	1x3's or 2x2's for 1x2's.
f3-f7	PVC plumbing for PVC electrical conduit.
c2	1-1/4" square thin galvanized foam (stick pin) washers for the 1" dia. fender washers.
c2	Various screws work well. A #6x1-5/8" coarse thread recessed square drive exterior or drywall screw is good, over-all. The bit, especially a magnetic bit, holds a square drive easier than any other. #6x1.5" hex washer head sheet metal screws cost more, but the washer head slightly reduces the risk of over-driving the screw through thin square washers.
c4	A more, or less, durable and costly roof film.

PURCHASE OPTIONS

1. Highlight the column of materials in Table 1 for your hangar and fax it to your nearest Home Depot or other store with your credit card number. When the store has assembled the materials, pick them up or have them delivered. Order remaining materials with the help of the preceding **Material sources**. Parts not available at most Home Depots, for example, are f3,4,14, c2,4-7, and t1.
2. Any one interested may assemble individual components into kits to sell and/or erect under their own name. Panel Inc. has no proprietary interest in the construction materials or method.
3. Options for airport owners
 - a. Build and rent hangars.
 - b. Charge a land use rental fee of say \$25-\$50/mo. extra per tie-down site for a plane owner who builds his/her own hangar, to be removed at any time specified by either party.
 - c. Combinations of options a and b.

Example of Option b: A plane owner buys Hangar #1 parts for \$1500, assembles them, and uses the hangar for 20 years, with a roof (c4) replacement at 10 years for say \$250. He pays the airport owner \$35/month (\$420/yr) extra to have the hangar at his tie-down site. His equivalent annual cost for the hangar, assuming 10% return on alternative investments, is:

$$\$420 + \$1500(0.1175) + \$250(0.3855)(0.1175) = \$608/\text{yr}$$
 equivalent annual cost, plus tie-down fee. Substitute appropriate values for your own situation.

HANGAR CHECK LIST

RESTRICTIONS (by zoning, building code, deed, or industrial park authority)		
This is a movable building (has no foundation), can be disassembled, and compactly shipped. Movable building permits are usually less restricted, and property tax is avoided.		
Floor area restrictions		
Allowed foot print area, based on lot size and existing building area.	_____	sq.ft.
Allowed extension from existing building, based on property line setbacks.	_____	ft.
Construction material restrictions		
Required fire rating _____		
If it abuts an existing building _____		
If free standing, _____ ft. from an existing building _____		
Profile shape restrictions		
Arch roof permitted?	Yes	No
Permitted with landscape screening?	Yes	No

NEEDS		
Desired storage dimensions		
Floor area	_____	sq.ft.
Height	_____	ft.
Volume	_____	cu.ft.
Door width _____ ft. by height _____ ft.		
Desired enclosure properties		
Vandal protection only:	Use only a security fence and alarm system?	
Protect from precipitation & sun only:	Roof only?	
Protect from wind, dust, humidity:	Add end walls?	
Day-lighted interior:	Translucent end walls?	
Desired floor		
Crushed stone over film moisture barrier, graded for drainage	_____	
Crushed stone over 1" insulation board over film	_____	
_____ inches of concrete over stone and film	_____	
_____ inches of concrete over stone, insulation board, and film	_____	
Other floor _____		
Desired environment		
Allowable temperature range:	_____ °F to _____ °F.	
(Fanfold has only R1.5 insulation, double layer R3)		
Other environmental requirements: _____		

COSTS (Provide own estimates for all but enclosure cost)	
First costs	
Enclosure (see TABLE 1)	\$ _____
Any grading and drainage	_____
Any floor (from above)	_____
Any alteration to an existing structure, as enlarging a door to the storage addition	_____
Any landscaping	_____
Recurring costs (capitalized at _____% interest)	
Film cover replacement @ 2¢/sq.ft. of floor/year	_____
Any property insurance requirement	_____
Any property taxes (should be none)	_____
Total Cost	\$ _____

DECISION	
Purchase?	Yes _____ No _____

Table 1. TYPICAL U.S. MATERIAL COSTS

Use this table to estimate costs of other hangarsizes.

Hangar No.		1		2		3		4		5		6		7		8		9		10		
Span x length x height, ft.		40x28x16		12x20x7		12x30x7		12x40x7		20x40x8		20x50x8		20x60x8		30x50x12		30x60x12		35x50x14		
No.	Frame	Unit \$	No.	\$	No.	\$	No.	\$	No.	\$	No.	\$	No.	\$	No.	\$	No.	\$	No.	\$	No.	\$
f1	Precut perim. stakes **	0.2	36	7	20	4	24	5	30	6	32	6	40	8	44	9	44	9	48	10	48	10
f2	1x2-8'	1.0	25	25	6	6	8	8	9	9	11	11	12	12	14	14	19	19	20	20	25	25
f3	4" PVC (2') sockets, 10'	10.6	2	21	0	0	0	0	0	0	0	0	0	0	0	0	0	0	0	0	0	0
f3a	3" PVC ribs, sockets, 10'	8.8	30	264	0	0	0	0	0	0	0	0	0	0	0	0	0	0	0	0	4	35
f4	2.5" PVC, 10'	7.0	0	0	0	0	0	0	0	0	0	0	0	0	0	4	28	4	28	40	281	
f5	2" PVC, 10'	3.6	0	0	2	7	3	11	3	11	3	11	4	14	4	14	32	116	40	145	0	0
f6	1.5" PVC, 10'	3.0	0	0	0	0	0	0	0	0	21	63	24	72	30	90	0	0	0	0	0	0
f7	1.25" PVC, 10'	2.0	0	0	8	16	10	20	14	28	0	0	0	0	0	0	0	0	0	0	0	0
f8	0.75" EMT purlins, 10'	2.2	69	148	14	30	21	45	28	60	44	95	55	118	66	142	75	161	90	194	95	204
f9	0.75" EMT couplings	0.5	46	23	7	3	14	7	21	10	33	16	44	22	55	27	60	29	75	37	76	37
f10	0.5" PVC sub-ribs, 10'	0.8	24	19	6	5	8	6	10	8	18	14	21	17	24	19	28	22	32	26	35	28
f11	PVC cement	2.0	2	4	1	2	1	2	1	2	1	2	1	2	1	2	1	2	1	2	2	4
f12	Self-lock nylon cable ties, 14" *	0.1	260	13	60	3	70	4	80	4	100	5	120	6	140	7	160	8	180	9	220	11
f13	7/8"x12' susp. ceiling angle **	2.7	(for doors)																			
f14	3/8" polyester strapping, 100'	1.5	8	12	2	3	3	5	3	5	4	6	5	8	6	9	7	11	8	12	9	14
f15	Treated 2x4 studs & posts		9-16'	72	4-8'	15	4-8'	15	4-8'	15	4-10'	18	4-10'	18	4-10'	18	6-14'	42	6-14'	42	8-14'	56
f16	4" nails, finish or common *			4		1		1		1		2		2		3		3		4		5
f17	Perf. plastic strapping, 10'	1.7	1	2	1	2	1	2	1	2	1	2	1	2	1	2	1	2	1	2	1	2
Cover																						
c1	3/8"-4x50' fanfold insulation	28.0	13	364	4	112	5	140	6	168	9	252	11	308	12	336	15	420	17	476	19	532
c2	1.5" screws and 1" washers	0.1	150	18	40	5	50	6	60	7	70	8	80	10	90	11	100	12	120	14	140	17
c3	3" tape, 100 ft.	3.0	1	3	1	3	1	3	1	3	1	3	1	3	1	3	1	3	1	3	1	3
c4	Roof film	.08/sf	30x60	144	20x20	32	20x30	48	20x40	64	30x40	96	30x50	120	30x60	144	40x50	160	40x60	192	50x50	200
c5	Floor tarp **	.08/sf	30x40	96	12x20	19	12x30	29	12x40	38	20x40	64	20x50	80	20x60	96	30x50	120	30x60	144	40x50	160
c6	3' corner fence posts	2.6	4	10	4	10	4	10	4	10	4	10	4	10	4	10	4	10	4	10	4	10
c7	1' tent pegs	0.6	8	5	6	4	10	6	10	6	10	6	14	8	16	10	14	8	16	10	14	8
Rib tools																						
t1	Socket driving cap & nipple **		3"	25	1.25"	10	1.25"	10	1.25"	10	1.5"	12	1.5"	12	1.5"	12	2"	15	2"	15	2.5"	20
t2	Rib props **	4.5	2	9	0	0	0	0	0	0	1	5	1	5	1	5	1	5	1	5	2	9
t3	Rib bending lever **	1.0	1	1	0	0	0	0	0	0	0	0	0	0	0	0	1	1	1	1	1	1
t4	Split pipe guides	6.1	2	12	0	0	0	0	0	0	0	0	0	0	0	0	2	12	2	12	2	12
Total mats, \$			1302		292		382		468		707		856		982		1218		1411		1684	
* Or shorter ties & nails for smaller rib diameters. ** Optional																						
Heights (row 1) are approximate. Greater increases snow resistance, less makes it easier to tie top purlins.																						
Includes material for both hangar ends, except for #1, having an aircraft door in one end (Fig. 12).																						

STEPS

Drive ground socket pipes



Insert PVC pipe ribs into sockets

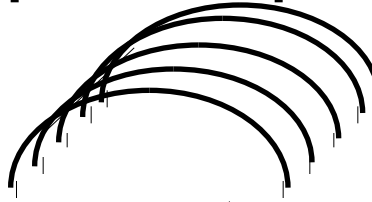

Tie metal pipe purlins to ribs

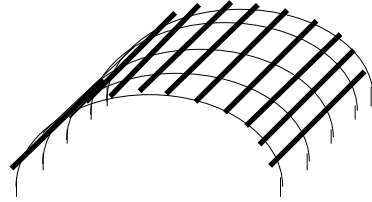

Tie small PVC pipe sub-ribs to purlins

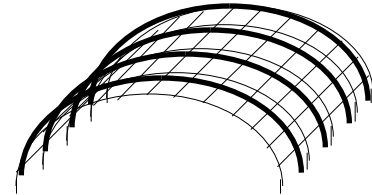

Tie wind and snow stiffener strapping

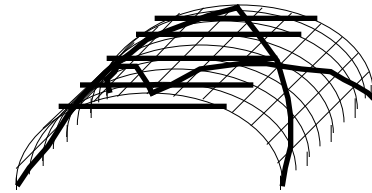

Frame end walls

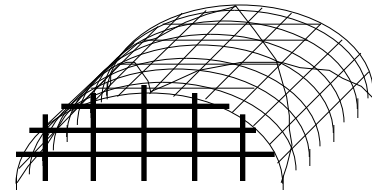

Face end walls with insulation board or alternative

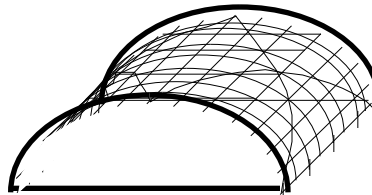

Pull fanfold over roof & anchor at two sides

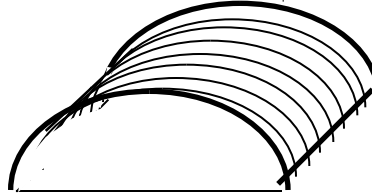

Pull tarp over roof and anchor at two sides and to corner posts
Frame door & add floor of choice

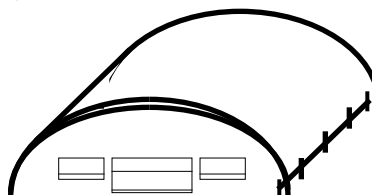

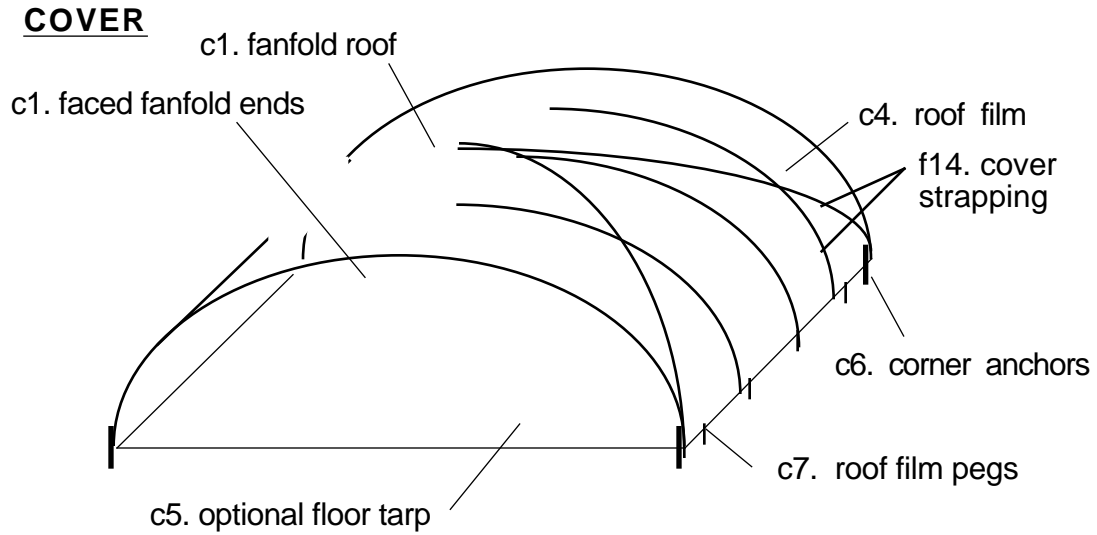
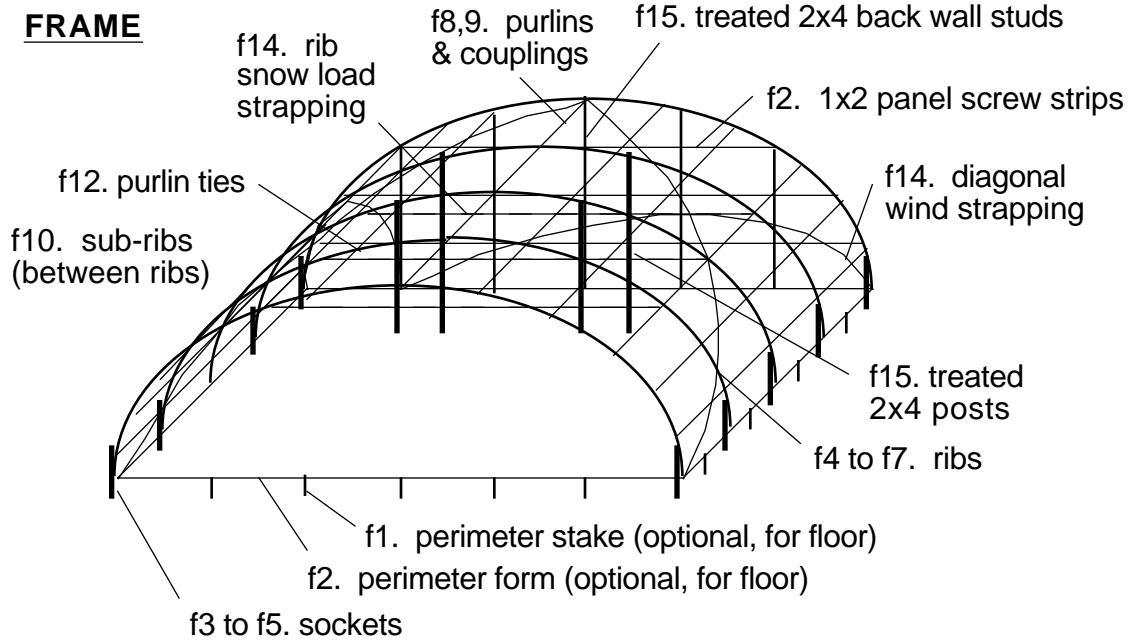
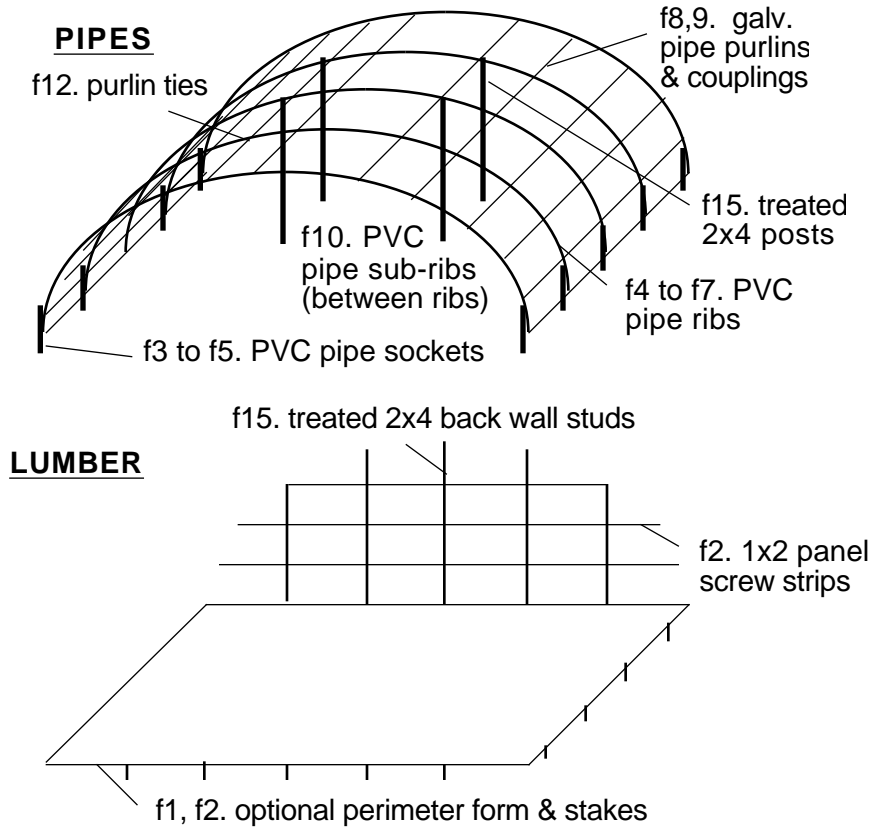
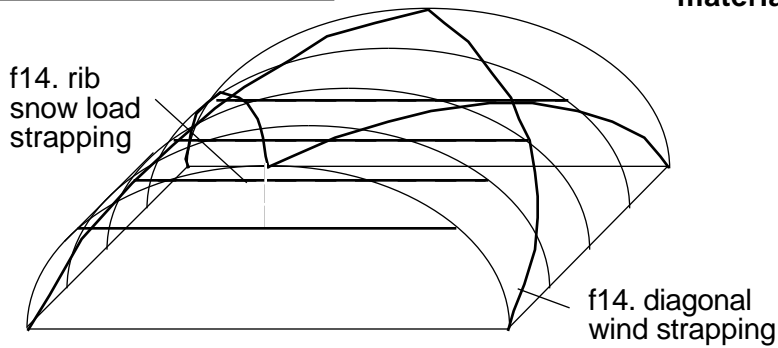

Fig. 1. Parts



TENSION STRAPPING

Fig. 2. Parts by material type



COVER

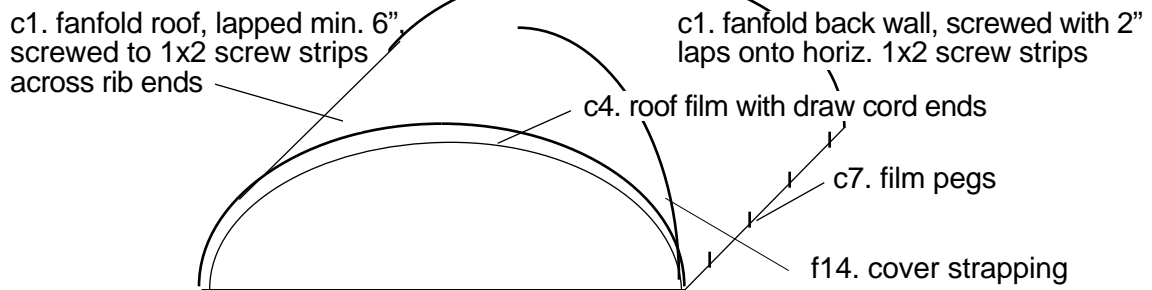

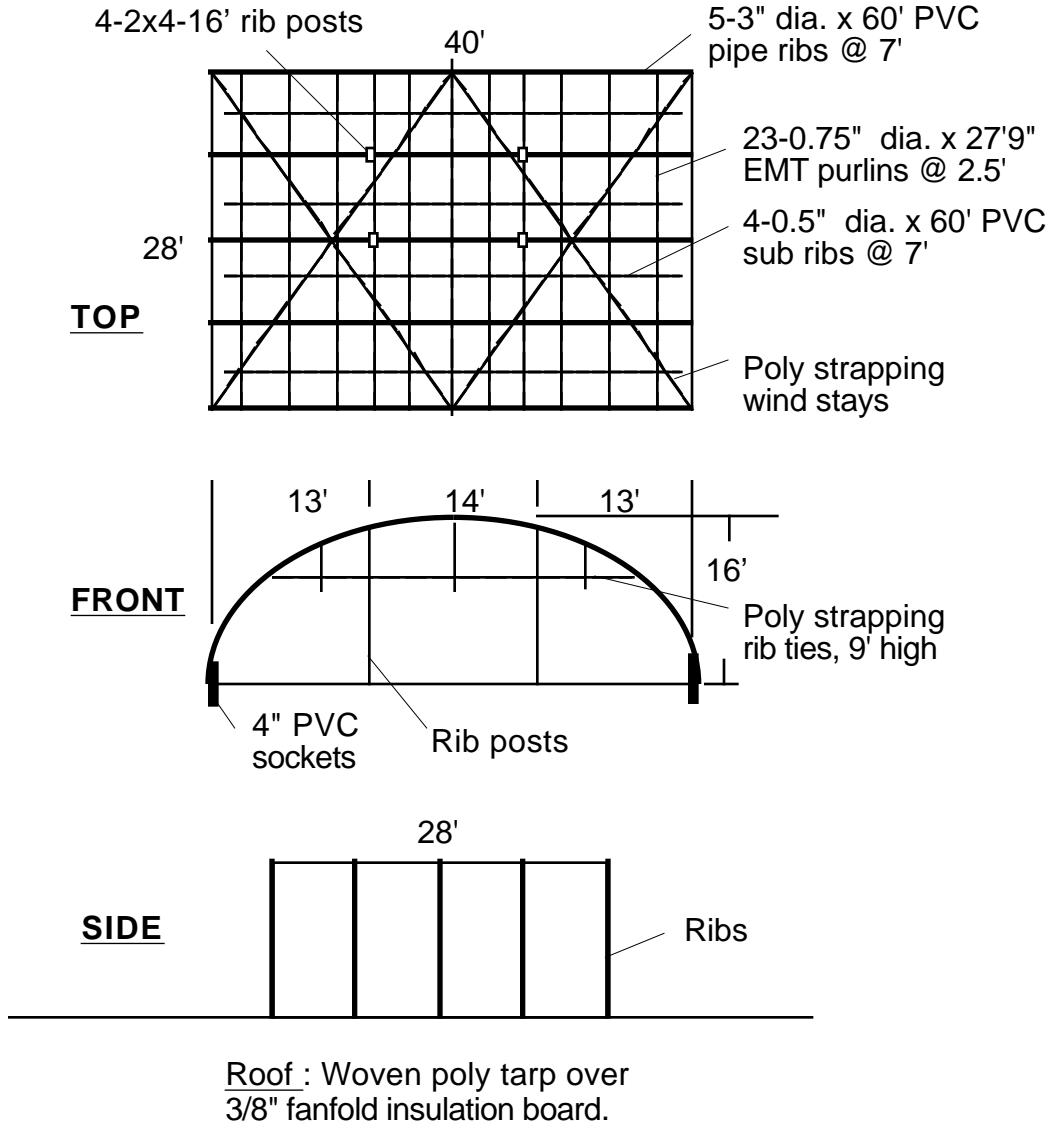

Fig. 3. Typical framing, Hangar #1, for aircraft

Disclaimer. Since this is a free guide for assembling components into a hangar, Panel Inc. makes no warranty on the assembled hangar.

ASSEMBLY TOOLS

<u>Tool</u>	<u>To</u>	<u>Assembly Step</u>
Tape measure	lay out sockets	1
Sledge, hammer	drive sockets, corner posts, anchor pegs	1
Hoe	level the earth perimeter	1
8 & 16' rib props	tilt up the bent ribs	1
Two wrenches	tighten purlin couplings	2
Pliers	tighten purlin ties	2
Ladder	tighten purlin ties	2
Utility knife	cut end walls at roof line	4

ASSEMBLY

Steps:

1. Insert PVC pipe **ribs** into ground sockets.
2. Tie **purlins** over ribs, and tie sub-ribs over purlins.
3. Add rib support posts, end wall **framing**, and stiffener ties.
4. Screw fanfold insulation board or other cladding to **end wall** framing.
5. Pull **roof** fanfold and film over the frame, and anchor them.
6. Cut and frame **doors** and any windows in the end walls.
7. Add any **floor** needed.

Details of each step follow. Part numbers in parentheses refer to Table 1. Photo numbers correspond to assembly steps. Lay out the photos to view each one as you read the corresponding construction step. Most photos are for the small No. 2 hangar in Table 1. Several photos show steps required only for the largest hangars (denoted by asterisks). The approximate hours following each step are average for one person the first time, assembling the largest hangar, No.1. Assembly time for the smallest hanger, No. 2, is less than 1/8th as long (less than 5 hours).

1. Ribs (~10 hrs)

- a. Rough grade the site, sloping it toward the door. Add and compact any crushed stone or other base material desired.
- b. Lacking any leveling device, check the direction of slope with a marble in a short piece of pipe.
- c. Locate the ground sockets by any means desired: using a 4' carpenter's square, 3-4-5 right triangles measured with a tape, or by the scheme shown in Fig. 4, for Hangar 1, consisting of:
 - (1) Set spikes or other markers at a and b, 28' apart, and at mid point c.
 - (2) Stretch a long cord between spikes a and b, setting spike d at its knotted midpoint.
 - (3) Measure 40' along c-d to set spike e.
 - (4) Swing a 40' arc about spike a and measure 14' from e to set spike f at their intersection.
 - (5) Extend line f-e 14' to set spike g.

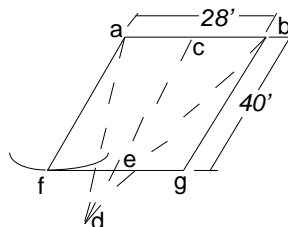

Fig. 4. Socket layout.

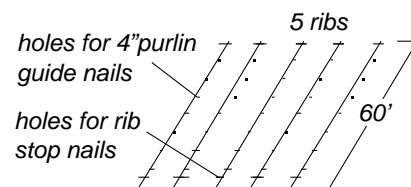

Fig. 5. Rib layout.

- d. Sockets drive easier after augering a pilot hole with a 1/2" electric drill and earth auger or any hand-held post hole digger.
 - e. Drive a 4" dia. socket with a sledge, centered at each of the six spikes, leaving about 8" project above ground. The pipe cap-nipple driving head (t1) can prevent damage to sockets.
 - f. Set a tool bucket near the middle of the site, to reduce walking.
 - Perform Steps g and h only if required for a poured floor.
 - g. Drive form stakes (f1) inside of the perimeter string, wrapped around the four corner sockets.
 - h. Nail the treated 1x2 perimeter form (f2) to the stakes, its top at string level. Bracing one foot against the back of the stake steadies it during nailing.
 - i. Saw the coupling end off of each rib, so it can fit into its socket. Drill holes 2' from each rib end for the two 4" stop nails (f16), plus holes at 2.5' intervals the full length of each rib for nails to rest purlins against while they are being tied to the ribs. Drill these holes through only one pipe wall, not clear through the pipe.
 - j. Lay out the ribs (Fig. 5). Glue ribs (f4 to f7) and sub ribs (f10) together. Use the printing on the pipes to visually align the drilled holes. Use PVC cement (f11) and pound ribs together from one end for a completely embedded tight coupling fit. Joints can distort during bending only due to poor gluing. If this happens, re-lay the rib flat and attach the couplings with screws (see Step 1s).
 - k. Tap the 4" nails (f16) into the holes at each end of the 5 ribs (Fig. 5). These control the depth of rib insertion into the sockets. Do not force larger nails into these holes; they may split the pipes. Then tap the nails into the rib holes at 2.5' spacings. These support the purlin ties (Step 2b). For smaller rib sizes, use nails 1" longer than the rib diameter. This allows enough projection to support the purlin ties, but not enough projection to snag fanfolds as they are tag-lined over the purlins and sub-ribs (Step 5d).
 - l. One person can easily set 20 and 30' ribs (Hangars 2 to 7) into their sockets by picking up one rib end, bending it, and pushing it into the socket. Propping the bent rib nearly upright with the 2x2-8' prop makes this easier. If one person must set 40 to 60' ribs (Hangars 1 and 8 to 10), the following Steps (1m to 1o) are helpful.
 - m* Drive the split pipe guides on short fence posts (t4) snugly over the two sockets for one rib, rotated slightly to one side, and clamp them to the sockets with the worm screw clamps, to help guide the rib into its sockets. These are made by simply bolting a short section of split socket pipe to a 3' fence post and adding a worm hose clamp to secure the post to the socket.
 - n* To set the rib ends into the sockets, bend the rib on the ground and lay its ends on top of the sockets. Now prop the bent rib into a tilted upright position, using the 2x2-8' prop (t2), then, for longer ribs, the 16'-2x4 stud having the J hook metal strap screwed to one end (also t2). Wobble one rib end down into its socket until supported on its stop nail, then the other rib end. Remove the J hook prop for reuse on the next rib.
 - o* For longer ribs, push down on the rib bending lever (t3) to align the rib into the socket. Vary your direction from the socket to accomplish this with ease. This lever is simply the 2x2-8' prop from step 1l with strapping attached to its lower end for looping around the rib above a purlin nail.
 - p. Drill a hole through the socket and rib, at least one socket dia. below the socket top, to avoid splitting it.
 - q. Reinsert the nail (f16) into this hole to anchor the rib to the socket.
 - r. Check socket alignment again after all ribs are anchored. Use the 8' 2x2 as a knee prop to pry sockets into alignment. Tamp earth or sand around the sockets and/or between each rib and socket to keep ribs aligned.
 - s. The following precautions prevent having to remove large ribs from their sockets to re-glue and re-screw loosened pipe joints:
 1. Mark the length of pipe to be embedded in each coupling, for visual confirmation of a tight fit after hammering it home.
 2. Drive each pipe joint home tightly with a sledge and wood block immediately after applying glue.
 3. Screw pipe couplings together with self-threading screws, placed especially at the outside of the bend.
 4. After glue hardening, bend each rib while it lies on the ground, to ascertain that sharper curvature does not occur at any joint, indicating joint weakness.
-

2. Purlins (~9 hrs)

- Cut the 3/4" EMT electrical conduit purlins (f8) with a pipe cutter or saw. Assemble the purlins with the compression couplings (f9). To mark purlins where they will cross ribs, lay the purlins side-by-side, roll thin adhesive tape across them at intervals equal to the rib spacing, and slice the tape between purlins to leave a tape indicator on each. Fanfold bundles make a nice work surface for this and other assembly steps.
- Lay a purlin on each row of supporting nails projecting from the ribs. Using pliers and a step ladder, tie the purlins on top of the ribs with the self-locking nylon cable ties (f12), at the crossing points of the nails in the ribs and the tape marks on the purlins. This keeps the frame aligned. Anticipate wasting a few ties in learning to tighten them without breaking. For spans over 35' (Hangars 1 and 10 in Table 1), use two crossing ties on each rib (Photo 2b). Tie purlins from the sides toward the center, the first ones loosely until correct rib alignment is assured. Purlins and ribs can be aligned by tapping them with a hammer. A purlin can be slid onto the previous purlin for temporary support before final positioning. For the top purlins on spans over 35', a 20' light extension ladder leaned against a previously-tied purlin and rib works well.
- Drill the end ribs and bolt the top purlin to them with carriage bolts. These bolts prevent the diagonal wind strapping (f14) from pulling the tops of the end ribs toward each other. The carriage bolts should be set in almost one rib dia. from the purlin ends to assure that cable ties do not slip off the ends of the remaining (tied) purlins.
- Tie the diagonal wind strapping (f14) over this pipe frame, between the bolted top purlins and opposite corner socket nails. Place the buckles between knee and waist height, where they can be easily re-tightened any time later. Tighten these four straps to plumb and square the frame.

Thread each side of the buckle by passing a looped end of the strapping under it, then up over its wire end (see instructions on container). Wrapping strapping through the crotch of the pliers to grip it twice reduces fraying due to plier slipping (Photo 2d).

- For hangar spans greater than about 30', tie rib cords with a strapping loop (f14) over bolts in each rib, just high enough to clear the highest stored object, such as 9' for an airplane tail. The lower the better for stiffening the rib against snow loads.
- Tie the 1/2" dia. PVC sub-ribs (f10) on top of the purlins half way between each rib, at ~7' intervals, to support alternate lapped 4' fanfold roof panels near their edges. (Remaining laps are supported over the main ribs, also spaced ~7'.) Closer sub-rib spacing should be used in heavy snow/ice regions. Ties near each end of each sub-rib plus one or two intermediate ties are adequate.

Photo 2 shows completed Steps 2 and 3.

3. Framing (~6 hrs)

- Set 2x4 end wall studs and any interior rib support posts into augured holes, and secure their tops by spikes projecting into holes drilled into the bottom of the rib (Fig. 6). Screw or nail the stud and post tops to the ribs with 3/4" wide perforated plastic strapping (f17).
- Screw horizontal 1x2 panel screw strips (f2) to the studs at 3'10" height intervals, to allow lapping the 4' fanfold by 2". Butt splice with short lapped 1x2's, or with the 7/8"x1' long angles (f13). Rest the spliced strips on finish nails set in the studs for support while screwing.

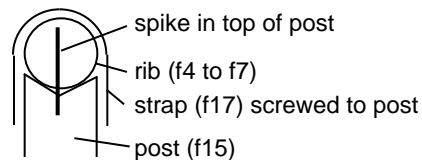

Fig. 6. 2x4 post top connection.

4. End walls (~4 hrs)

Table 2 lists some end wall cladding options, depending on the hangar's purpose and on local material availability.

Table 2. SOME END WALL CLADDING MATERIALS

Material	Size	Typical cost/sq.ft.	Thermal resistance	Notes
Foil-faced fanfold	3/8"x4'x50'	14¢	R1.5	Such as Tenneco - Amacor PA14.
Aluminum- or vinyl-faced insulation boards	1/2" to 1"x4'x8' sheets	21 to 40¢	R2 to 6	Such as Celotex, Georgia Pacific, Owens-Corning, etc.
Twin-wall corrugated greenhouse plastic	5mmx4x8' or 4x12' sheets	75¢	R2.5	If translucence is required. Greenhouse sources.
Any wood or vinyl sheet cladding	Varies	Varies	Varies	May be locally more available.
Woven film, similar to roof, or translucent	Size needed	10¢, with trimmed waste	Negligible	Cheap, less durable. *

* Omit the end wall horizontal screw strips. Batten the tarp to the outside of studs with 1x2's. Add an exterior horizontal batten strip at ground level. Wrap the tarp over the top of pipe rib (slit at purlins) and staple it to the insides of the studs.

The following steps are for fanfold cladding (the first material in Table 2).

- Unfold and screw the 4' bottom back wall panel (c1) to the screw strips (f2) along its top and bottom with screws and fender washers (c2), or 1" square stick pin washers (Photo 4a). A cordless drill saves trailing a power cord.
- Hang the next panel layer on its upper screw strip with the spring hand grip and bolt hangars (Photo. 4b), by hanging on the finish nails from Step 3b, which poke into the insulation board, or by other means. Screw it similarly, flattening the panel folds as each screw is set. Repeat to the top of wall. Mount panel lengths which are easy to handle, such as 50' at ground level or 25' on a step ladder. Tape (c3) any vertical panel joints after they are mounted, to provide a weather seal.
- Cut panels off at the roof line (at the tops of purlins) with a utility knife.
- Screw panels to the end ribs. Punch holes in panels for purlins if the purlins project beyond the end ribs. Simply pound the panel over the purlin end with the heel of your fist to punch a hole.
- Poke holes through the fanfold with a nail from inside the hangar to locate any screws into wall studs from the outside.

Photos 4 show the hangar front (with door) and back after completing Step 4, with roofing fanfold and film for Step 5 stacked inside.

5. Roof (~14 hrs)

Fanfold placement

- Drive the four 3' corner fence posts (c6) for roof film anchorage. 1' tent pegs or screw anchors can be used instead of fence posts for the smaller hangars, depending on soil type.
- Tape wires to the fanfold ends for tag-lining. 1' or longer suspended ceiling wire hangers, straightened wire coat hangers, or welding rods anchored with duct tape work well. For smaller buildings, omit the wires and just lay fanfold bundles on their edges on top of the frame and let them unfold down each side.
- Tape on extra fanfold panels if needed to obtain the required arch length, at the opposite end from the wires. This can be done by first taping the inside of the fold with adjacent panels laid flat and tightly abutted, then folding them to tape the outside of the fold. This assures correct tape spacing on each side of the fold.
- Tagline the fanfold (c1), using any polypropylene twine, 1/8" braided nylon, or similar light cord. Lay the folded panels along one side, tie one end of the tagline through the wire-reinforced

- end of one panel, and throw the other end over the frame to pull the fanfold up over the frame. The fanfold slides easily if it is laid so that at least half of the panel slides on the previous panel as it is pulled over the frame. The panel can then be moved with the prop so that it laps the prior panel by some lesser amount, such as 6". The fanfold can also be pulled over the frame by standing inside and tag lining around a lower purlin while gently lifting the fanfold overhead with a prop in the other hand.
- e. To return the tagline over the roof for each panel, either (1) coil the line and throw one weighted end back over, or (2) use a double-length tagline so it can be hauled back across the hangar for the next panel.
 - f. Screw one end of each fanfold to the 1x2 screw strip mounted across the ribs near ground level. A single screw and washer (c2) at each lapped joint is adequate.
 - g. Tension the fanfold by hand as much as possible and slice off any excess panel on the opposite side. Screw the roof end panels to the end ribs at 3 or 4 points, midway between purlins, to help anchor them in place.
 - h. Lace a ball of twine back and forth over the fanfold panels and around the socket nails (f16) or around tent pegs to hold the fanfold down until it can be covered with the roof film. If fanfold tears loose in a storm before it is anchored down with roof film, slice it along folds with a butcher knife and tape remaining good sections together with duct tape.

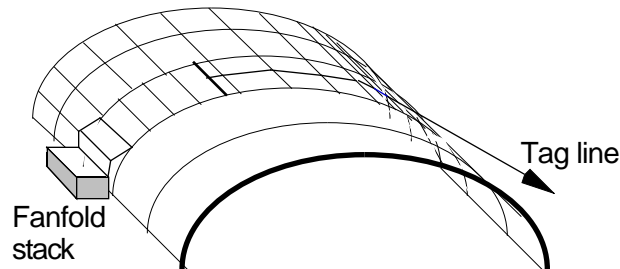

Fig. 7. Step 5d, fanfold placement.

Roof film placement

- i. Punch holes, spaced about 18", in the film ends to lace strapping (f14) through. This provides a neat looking end closure and eliminates wind flapping at the roof film ends. A hand punch (shown) is convenient, or poke holes with a spike, awl, or knife. These are low stress points and need no grommets.
- j. Lay the film along the side of the hangar. For large hangars, loop a PVC pipe or 1x2 to the grommets on one side of the film. Tie a tagline to the center of the pipe or 1x2. Pull the film over the fanfold with this tagline. For large spans (Hangars 1 and 10 in Table 1), the following techniques can simplify the pulling:
 - (1*) Lay the film beside the hangar in accordion folds to eliminate its friction against the ground during pulling.
 - (2*) Use an anchored pulley (Photo 5j2*) to reduce required tension by half.
 - (3*) If two persons are available, the second can prop up the film to reduce its friction against the underlying fanfold as it is pulled.
 For small hangars, just pull the film over with tag lines from the two corners, especially if two people are available.
- k. Tie the four corners of the film (c4) to the corner posts (c6) for temporary wind anchorage.

Film anchoring

- l. Tighten the end strapping to the corner posts to stretch the film lengthwise over the ends.
- m. Screw a treated 1x2 batten over the film into the 1x2 screw strip previously screwed or lashed to the ribs, Step 5f (Fig. 8). Space screws close enough for good friction clamping of the film between the two 1x2's. This anchors the film and fanfold for the full length of each side.
- n. Berm both sides with soil to cover the film edges by at least 3" to prevent access by wind.
- o. Inspect the interior for any panels which do not lie flat against the frame. Simply slice them at a fold with a utility knife, lap flat, and tape the lap. Carefully hold the knife flat enough so it does not cut through to the film.
- p. Finally, stretch cords tightly between socket nails (over the ribs) and diagonally between corner posts to reduce ballooning of the film in gale winds. This is helpful for large span hangars like Hangar #1. See Step 5e for easy ways to pass the cord across the roof.

6. Doors (~3 hrs)

- a. Cut openings in the end walls to frame doors of desired size. Light doors can simply be a 1x2 outer frame screwed to a 1x3 backer to serve as the door jamb (Fig. 9). 7/8" suspended ceiling angle screwed to a 1x2 makes a neat light door edge. This works for both vertically and horizontally hinged (awning) doors, which can be propped open with anything handy, like PVC pipe.

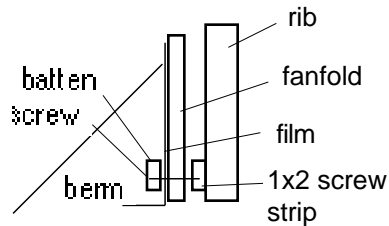

Fig. 8. Roof film edge connection

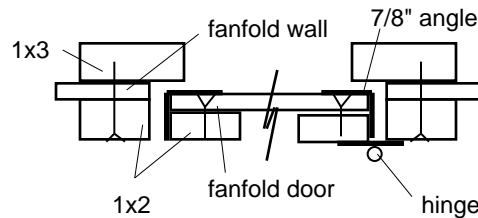

Fig. 9. Door framing

Disassemble hangars in the reverse sequence for moving. The parts which cannot be reused are the cable ties (f12) and strapping (f14). Saw ribs into convenient lengths for transporting, such as 20', and buy PVC couplings to rejoin them.

Caveats. (1) Lace the roof down in case of unexpected wind during construction. (2) The hangars are flexible: expect creaking of foam board against ribs during winds.

ASSEMBLY OPTIONS (numbers keyed to assembly steps)

1c. Socket layout. To lay out several hangars of the same size, save time by using a light weight film ground template with edges marked for socket locations.

1n. Tilting up long ribs. A gin pole can also be rigged to tilt up large arches. After bending the rib ends onto its socket tops, tie a hoist line from the center of arch across an eye screw in the top of one of the 2x4's to be used as end wall studs, then through an anchored pulley. Tie the hoist line back onto itself after pulling the rib almost vertical. Then wobble each rib end into its socket.

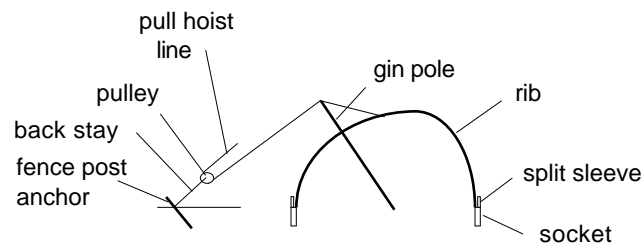

Gin pole for rib tilting

2b. Purlins can be attached with screwed U- or strap-clamps instead of with nylon cable ties.

2d. Strapping options. Materials other than polyester strapping (f14) can be used. Advantages of polyester are its high stiffness/cost and strength/cost ratios, it knots easily, requires small volume and weight, and the buckles provide an easy way to re-tighten it during service. The tensile strength exceeds 500 lb. If strapping breaks, just tie in another piece.

3. Framing. In addition to rib cord strapping and support posts, large span ribs can be stiffened with bolted 1x6 (or sheet metal angle) scissors trusses shown in Fig. 12. Bolt the two 8' side 1x6's

to the rib, then hoist the 3-16' 1x6's to approximate position with a string attached to a screw set in the top edge at the center of each 1x6. Then bolt these three 1x6's to the rib and screw them together at their crossing points to prevent buckling.

4a. End wall options.

Number: Two end walls (free-standing), one end wall (attached to a building), or no end walls (open ends).

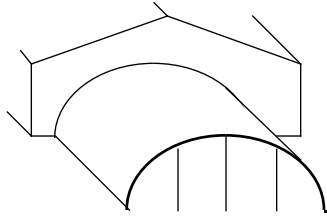

Examples: Attached

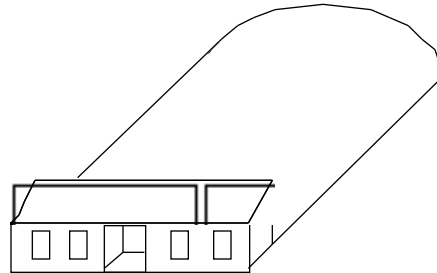

With office front

It is easiest to mount end wall panels and trim them to shape before covering the roof. But if quick shelter from sun or rain is important, the pre-mounted roof film end strapping can be loosened from the corner stakes, then the end wall panels mounted and trimmed before re-tightening the film over them.

5b. Fanfold options. Lap the roof fanfold (c1) at least 6" to prevent long-term separation due to wind racking. Items f10 and c1 in TABLE 1 are for a 6" lap of the 4' wide fanfolds (one sub-rib and two fanfold panels between each two ribs, spaced ~7'). For two sub-ribs and three panels between each two ribs, multiply item f10 by 2 and item c1 by 1.5. For more insulation (R3), buy and lap a complete double layer of fanfold. For still more insulation it becomes cheaper to buy 2" thick (R8) or greater expanded polystyrene (EPS) panels faced with adhesive-bonded fabric which serves as hinges at folds. Inquire of Panel Inc.

5i. Roof film options. Purchase any grade of roof film desired. Whether you buy high or low cost roof film, count on 1¢ to 3¢/sq.ft./year for film replacement, depending on climate and exposure (comparable to costs of asphalt shingle roofing). UV-treated woven 14x14 polyethylene tarps, silver top side, black under side, with 18" grommet spacing and heavy duty corner grommets, work well. The next higher quality is vinyl film in various mil thickness. Roof film can be used without the supporting fanfold if sub-ribs are spaced more closely near the top to prevent water pockets.

5i. Sky-lighting is desirable for pool and tennis enclosures. A simple method is to leave gaps between some of the roof fanfold and cover the roof with translucent vinyl or woven polyethylene instead of opaque film, and/or to use translucent film or panels on one or both ends. Use foil-faced roof panels to protect them against sunlight under the translucent film, and expect a higher annual cost of film replacement than for opaque films. Weigh the need for sky-lighting against the need for insulation.

5i. Film end options. When an end wall is omitted, the roof film end strapping can be tightened back under the end rib, instead of to corner posts, to give a neater end appearance. For example thread a 1/2" PVC pipe through the end strapping between grommets and lace this pipe back to an interior rib, or to the opposite film end if both end walls are omitted. Use additional purlin-to-end rib bolts to insure against end ribs being pulled inward by the added roof film tension.

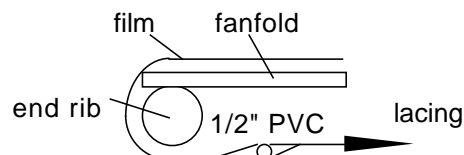
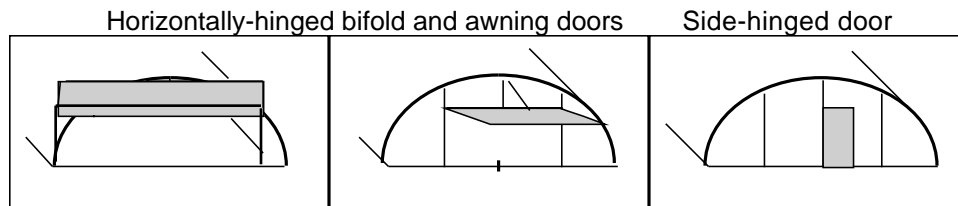

Fig. 11. Film wrapped under end rib.

5m. Batten options (Fig. 8). On hangars over about 30' span, longitudinal racking in strong winds is reduced by adding a second batten on each side as high as one can easily reach from a step stool. Screw this batten through the fanfold before adding the roof film. this connection adds structural continuity to the rib-stiffened shell.

6a. Door options



Large doors. Hangar arch length may be dictated by door size, as for aircraft, boat, farm combine, and construction equipment hangars. Draw the required door outline on grid paper and pin a bendable piano wire, balsa or plastic strip or construction paper arch over it to determine required arch length.

Roll-up film aircraft doors

Aircraft doors require trade-offs in weight, cost, operating convenience, maintenance, etc. A roll-up film door (Fig. 10) is light enough to be raised by awning cords and its flexible bottom pipe roller allows tail and wing clearances with minimal door-opened area in a quonset-shaped hangar. It is a lower thermal protection, lower cost alternative to bifold or horizontal track doors. Film doors flap in winds, but are inexpensive to replace.

Materials

Film Use the same film as for the roof, or a translucent woven film for day-lighting, or thermal blanket material for better insulation. A 20x40' tarp can be used for the plan shown in Fig. 10.

Framing (bolted to the inside of the front rib). 5-1x6's (2-8', 3-16').

Assembly (Photos Do and Dp)

- Bolt the 5-1x6's lapped inside of the front rib with 6" bolts.
- Lay the 20x40' tarp on the ground in front of the hangar and clamp it onto a 1"-40' PVC pipe about 8" from one edge with split 1" PVC pipes held with screws (Fig. 10). Add a small eye bolt every 7' to 8'. The pipe is a flexible bottom roller to anchor the door closed or to roll it open like an awning.
- Drive 12" or longer tent pegs, one adjacent to each eye bolt, along the door bottom for wind anchorage. Connect each tent peg and eye bolt with the shortest available (10" or less) shock cords.
- Stretch the free 40' tarp edge over the front rib (slit it at the purlins) and staple it to the backs of the 1x6's. Keep the tarp taut with cords from its edge grommets to the same tent pegs, while stapling. Then trim away excess tarp below the 1x6's and batten it to the fronts of the 1x6's with 1x2's.
- Knot the center of each shock cord to shorten it, providing added tension for wind anchorage.
- Tie the awning cord ends to eye screws at the outside of the two sloping 1x6-16's. Pass the center loop under the roller and inside over the top purlin, for rolling the door open (Fig. 10). Photos Do to Dq show a similar door opened and closed and a rear view of Hangar #1 (40' span by 28' aircraft hangar).

Door operation To open the door, unzip the Velcro door flaps at the two sides from the roof. Unhook the shock cords from the eye bolts in the 1" PVC pipe at the bottom of the door film.

They can lie on the floor, permanently hooked to the anchor pegs. Pull down the center loop in the cord to roll up the door to the door frame. Cinch the loop to a side purlin above the plane wing height, to keep the door open and curved to above tail height in the center. Twisting the roller by hand while raising the door gives a tighter wrap of the film. Otherwise it can just be left bunched against the roller.

To close the door, reverse these steps: attach the shock cords, step outside and secure the two Velcro flaps.

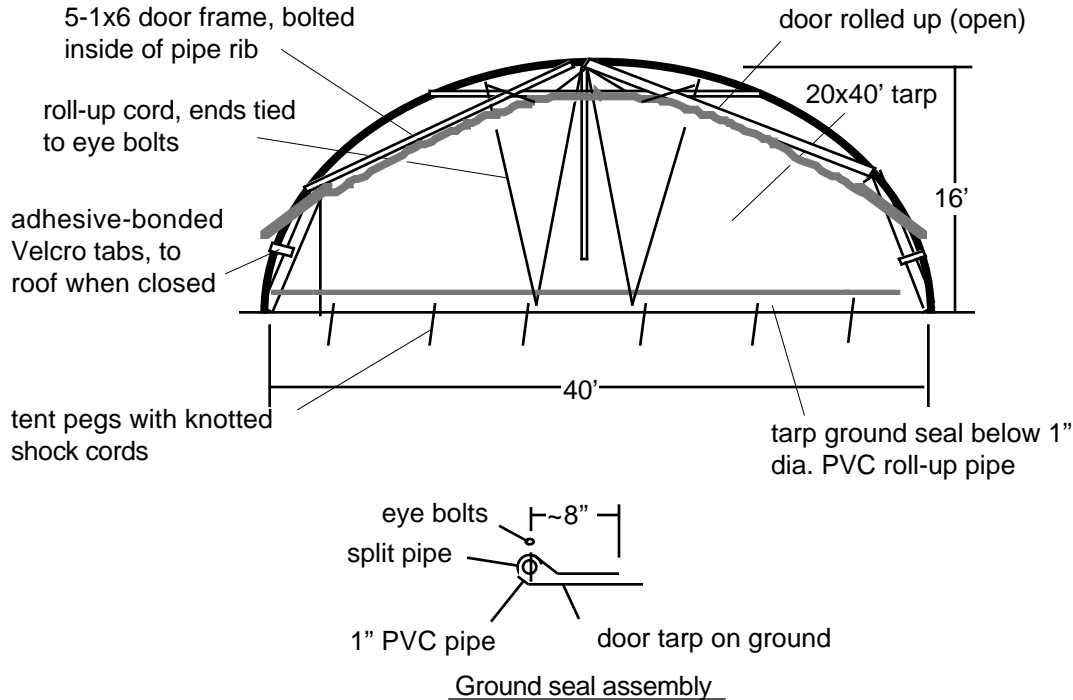

Fig. 10. Roll-up aircraft door

8. Floor options. A film similar to the roof film can be stretched over any prepared surface and battened to a perimeter form. Surface preparation can be as simple as plate-compacted stone dust. This is adequate where ground moisture sealing is important but abrasive or concentrated loads are infrequent, as for aircraft hangars. Wood planks or steel C channels can be laid to carry heavier wheel loads, before investing in a rolled asphalt or concrete floor.

MAINTENANCE TIPS

1. Roof films deteriorate in sun light. Discoloration and embrittlement are the clues. Turn the film over, or replace it with new film.
2. Hangar leans endwise. Loosen, then tighten the appropriate diagonal wind strappings to plumb the hangar. Also, add more diagonal strapping from the appropriate corner sockets to the opposite rib.
3. Hangar leans sidewise. Add rib knee braces to one side to plumb the ribs, or strapping between the appropriate sockets and corresponding rib peaks.
4. Rib deflects under heavy snow load. Tighten rib cord strapping. Add temporary rib props or permanent posts.
5. Any strapping loosens. Re-tighten at the buckles with pliers.
6. Purlin ties loosen. Re-tighten with pliers.

7. Panels puncture by equipment or other impact. Tape over the panel crack, or cut out and tape in one or more 2x4' panel sections.

8. Roof film punctures by impact. Repair with duct tape or other UV- and moisture-resistant tape.

ABOUT PANEL INC.

Panel Inc., a 501c3 non-profit corporation of Delaware, donates storage buildings to tax-exempt 501c3 charities. It has no paid employees, solicits no funds, and accepts no government funding. All income is donated to 501c3's. Its president, Robert Nicholls, a registered engineer and civil engineering professor emeritus at the University of Delaware (1959 to 1993), provides services in construction management, materials, and geotechnical engineering.